

ST-5221

Serial Interface, RS422 Communication, 1 Channel

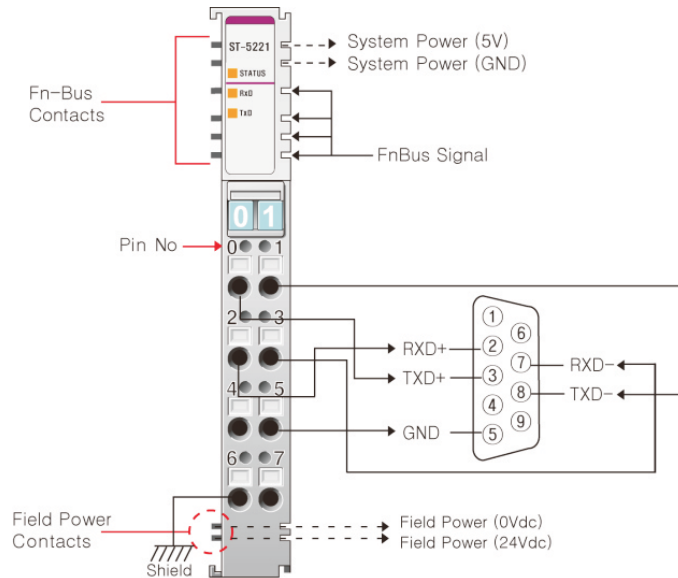

Item	ST-5221	
Interface Specification		
Transfer Channels	TxD, RxD, Full duplex	
Transfer Rate	300 ~ 115200	
Data Bit	7 bit, 8 bit	
Parity Bit	None, Odd, Even	
Stop Bit	1 bit, 2 bit	
Flow Control	RTS, CTS	
Bit Distortion	<1.6%	
Connection	Spring force of RTB	
Cable Length	1km twisted pair	
Low Signal Voltage	-	
High Signal Voltage	-	
Isolation	Isolation Voltage : 1000Vrms/Vac	
RxD Buffer	1024 Byte	
TxD Buffer	256 Byte	
Line Impedance	120Ω	
Input Image Size	6 Byte	
Output Image Size	6 Byte	
General Specification		
Power Dissipation (System)	155mA max @5.0Vdc	
Operating Temperature	-20℃ ~ 55℃	
Non-Operation Temperature	-40℃ ~ 85℃	
Relative Humidity	5% ~ 95% Non-condensing	
Operating Altitude	2000m	
Shock Operating	30g	
Shock Non-Operating	50g	
Vibration	2g@10-500Hz	
Module Size	12mm x 99mm x 70mm	
Environment Condition	Refer to " Environment Specification"(page : 1-191)	
Pin No.	Description	
0	TxD +	
1	TxD +	
2	RxD +	
3	RxD -	
4	GND	
5	GND	
6	SHIELD	
7	SHIELD	
LED NAME	COLOR	STATUS
RxD	Green	Received Data
TxD	Green	Transmit Data
-	-	-
-	-	-